

The OKK logo is rendered in a bold, white, sans-serif font in the top left corner. The background of the entire page is black, with a series of thin, white, parallel lines that create a 3D perspective effect, receding from the top right towards the bottom left.

OKK

Large Capacity, High-Speed Horizontal Machining Center

HM1600

Large Capacity, High-Speed Horizontal Machining Center

HM1600

Combining exceptional cutting capability with high-speed and accuracy to optimize the machining of wind-power amplifier gear boxes, large-size dies and molds, diesel engine blocks and other large products.

Travel Distance

2400(94.49") X **1650**(64.96") X **1750**(68.90") mm

Pallet Size

1600 (62.99") X **1250**(49.21") mm

Maximum Workpiece Size (Diameter × Height)

Ø**2500** (98.43") X **1850**(72.83") mm

Rapid Traverse Rate (X/Y/Z axes)

42m/min(1654ipm)

Maximum Tool Mass

30kg(66.1lbs)

Maximum Tool Diameter

Ø**300**mm(11.81")

Maximum Tool Length

600mm(23.62")

Number of Stored Tools

60tools

*116, 176 or 236 tools can be stored optionally.

Maximum Load Mass

5000kg(11013lbs)

*8000 kg (17621lbs) or 10000 kg (22026lbs) can be loaded optionally.

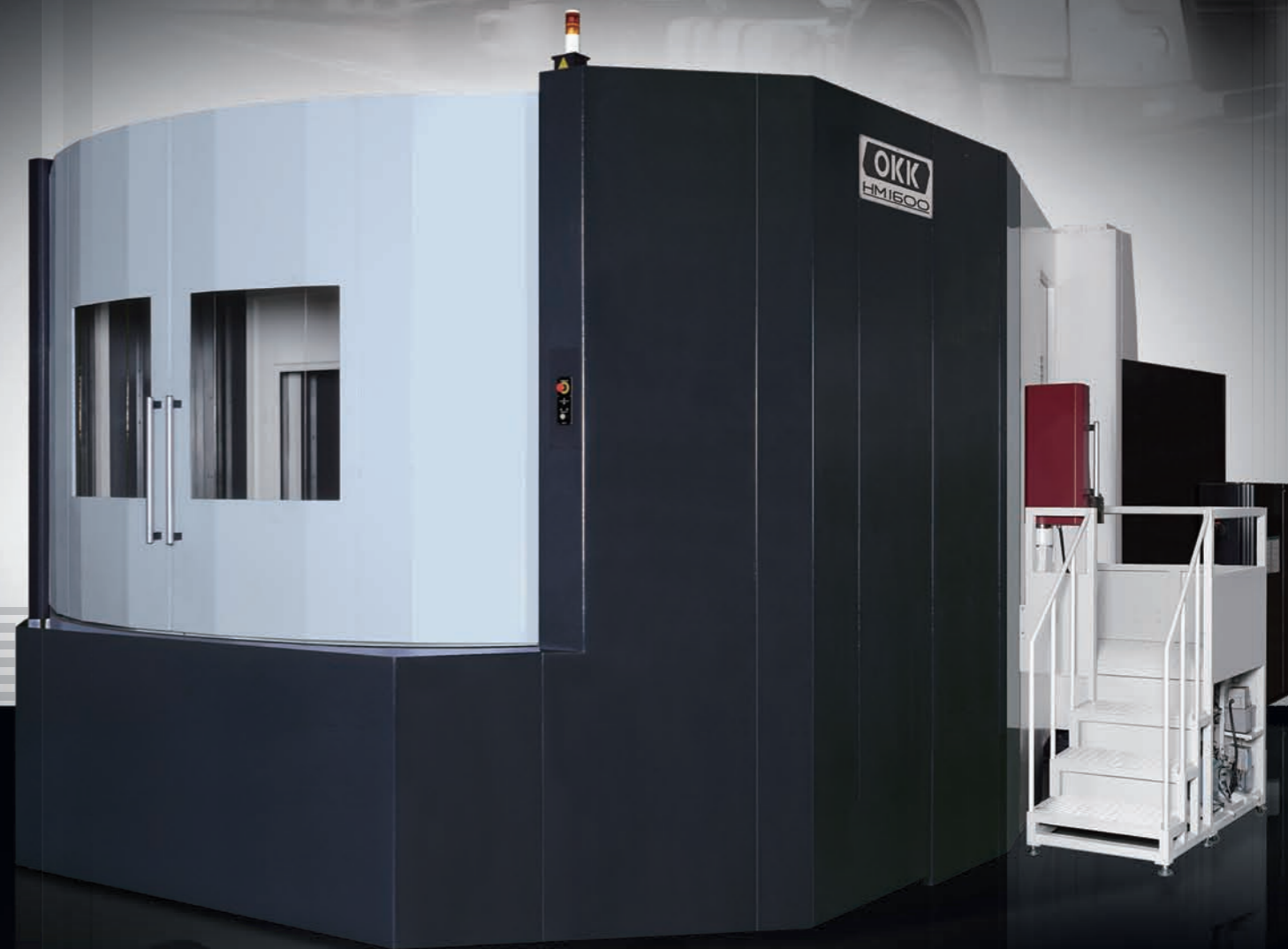

Consistent machining performance is received by the precise synchronization of the control and the drives.

Synchronized control of the Y and Z axes drives and the large-diameter twin-lead ball screws

Provision of various types of spindles to respond to any users' demands

Three types of spindle specification.

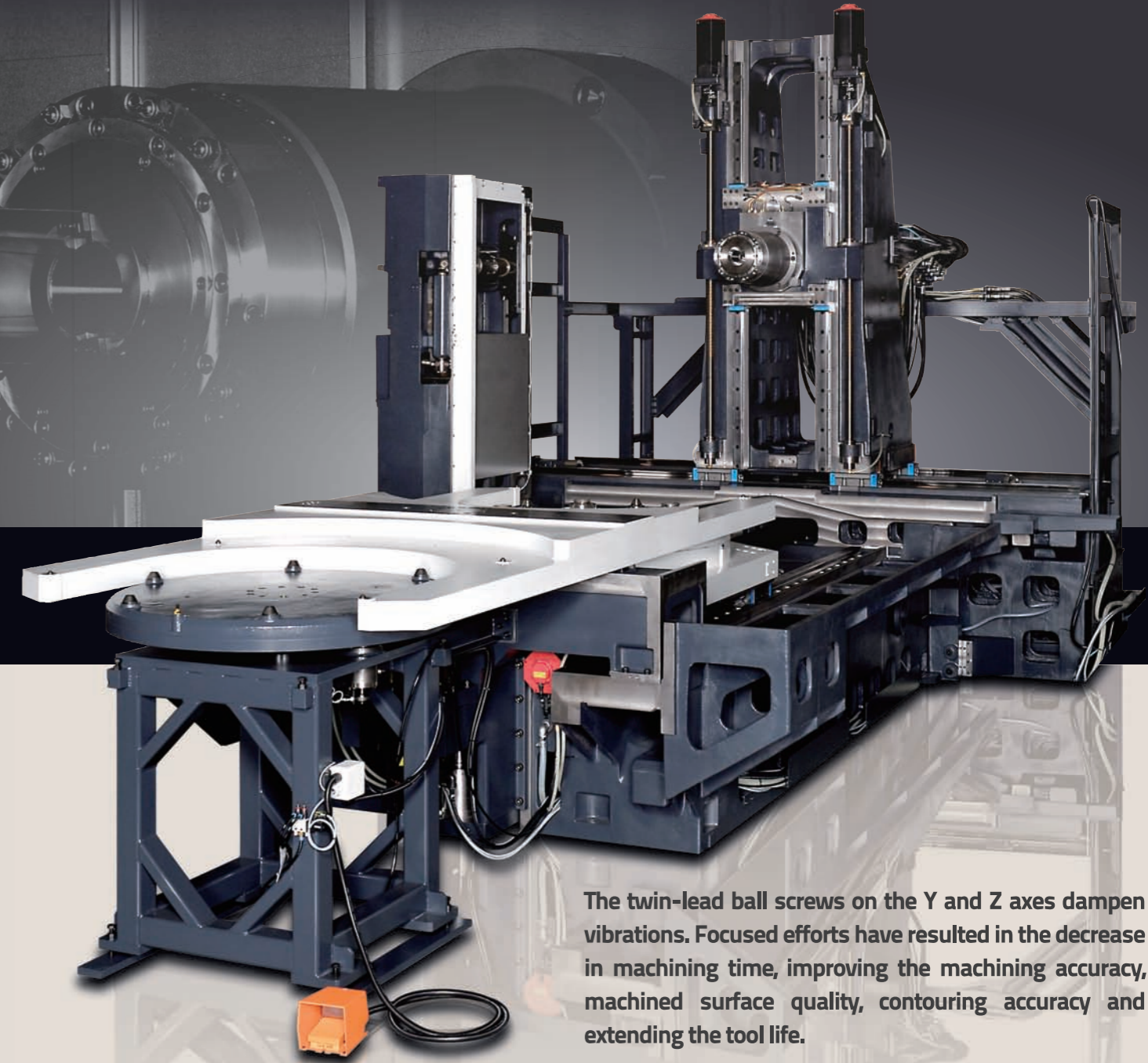

The twin-lead ball screws on the Y and Z axes dampen vibrations. Focused efforts have resulted in the decrease in machining time, improving the machining accuracy, machined surface quality, contouring accuracy and extending the tool life.

High-speed Spindle (MS)

For high-speed and high efficient machining of general parts

Spindle rotating speed: 35 through 12000 min⁻¹
 Spindle motor: 30 kW (40HP) (30-min rating) / 25 kW (34HP)(continuous rating)
 Maximum spindle torque: 420 N·m (310ft·lbs)(25% ED rating) / 238 N·m (176ft·lbs)(continuous rating)
 Spindle bearing bore diameter: ø100 mm (3.94")

Optional Output-increased Spindle Motor

Spindle motor:
 40 kW (54HP)(15% ED rating) / 25 kW (34HP)(continuous rating)
 Maximum spindle torque:
 600 N·m (443ft·lbs)(15% ED rating) / 304 N·m (224ft·lbs)(continuous rating)

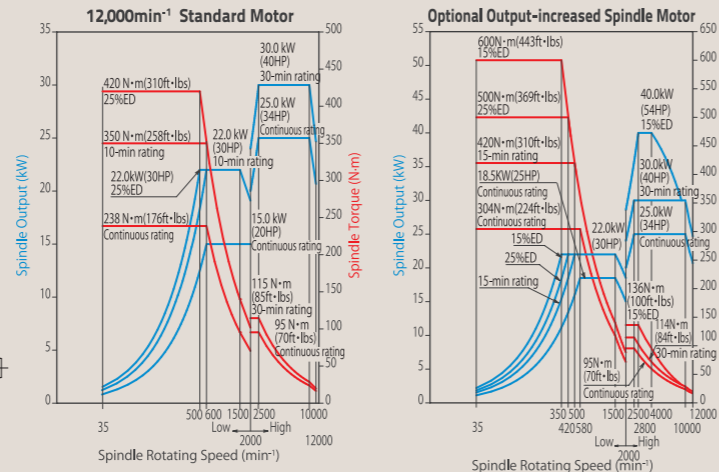
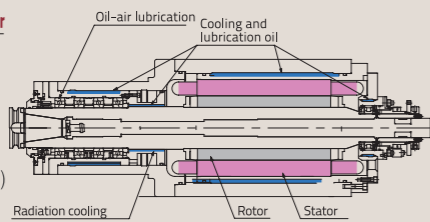

Gear-drive Spindle (Three-step Gear Drive)

For smoothly machining the hard-to-cut materials for heavy-duty parts

Spindle rotating speed: 20 through 8000 min⁻¹
 Spindle motor: 18.5 kW (25HP)(30-min rating) / 15 kW (20HP)(continuous rating)
 Maximum spindle torque: 1052 N·m (776ft·lbs)(30-min rating) / 853 N·m (629ft·lbs)(continuous rating)
 Spindle bearing bore diameter: ø120 mm(4.72")

Optional Output-increased Spindle Motor

Spindle motor:
 30.0 kW (40HP)(5-min rating) / 18.5 kW (25HP)(continuous rating)
 Maximum spindle torque:
 1705 N·m (1258ft·lbs)(5-min rating) / 1052 N·m (776ft·lbs)(continuous rating)

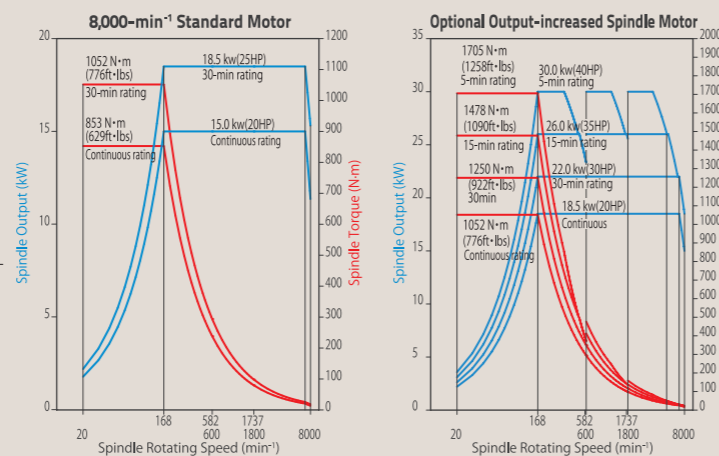
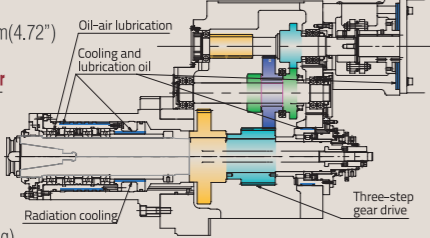

Two Position Locking Quill Style Spindle (Three-step Gear Drive)

The two position locking quill spindle can realize with a single chucking operation the machining that required two processes using the machining center and the boring machine. It allows a drastic reduction in the total machining time by reducing both the processes and the setup work that can take hours for the large-size parts.

Spindle rotating speed: 20 through 4000 min⁻¹
 Spindle motor: 18.5 kW (25HP)(30-min rating) / 15 kW (20HP)(continuous rating)
 Maximum spindle torque:
 1000 N·m (738ft·lbs)(30-min rating) / 810 N·m (597ft·lbs)(continuous rating)
 Spindle bearing bore diameter: ø110 mm (4.33")
 Quill spindle outside diameter: ø110 mm (4.33")

Optional Output-increased Spindle Motor

Spindle motor: 26.0 kW (35HP)(10-min rating) / 22.0 kW (30HP)(15-min rating) / 18.5 kW (25HP)(30-min rating) / 15 kW (20HP)(continuous rating)
 Maximum spindle torque: 1402 N·m (1034ft·lbs)(30-min rating) / 1186 N·m (875ft·lbs)(30-min rating) / 1000 N·m (738ft·lbs)(30-min rating) / 810 N·m (597ft·lbs)(continuous rating)

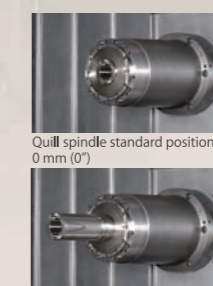

Quill spindle standard position: 0 mm (0")

Quill spindle extended position: 300 mm (11.81")

Quill spindle positioning in two positions (0/300 mm)(0"/11.81") OKK's original clamp device minimizes the drop in machining capability when the spindle is extended. (Patent pending)

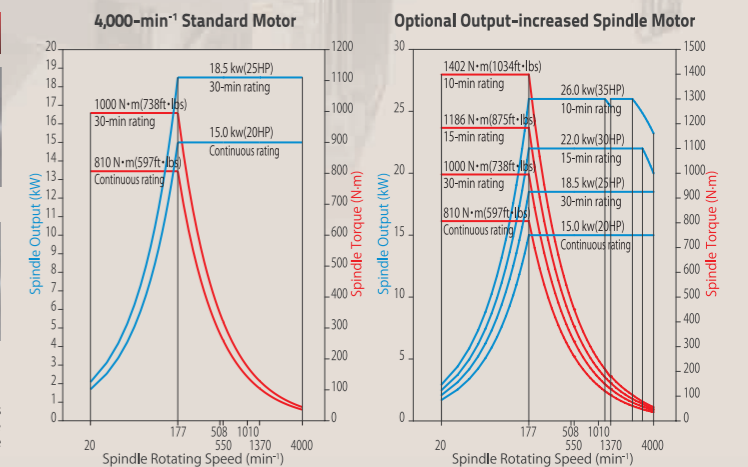

High-accuracy Positioning and High Clamping Force

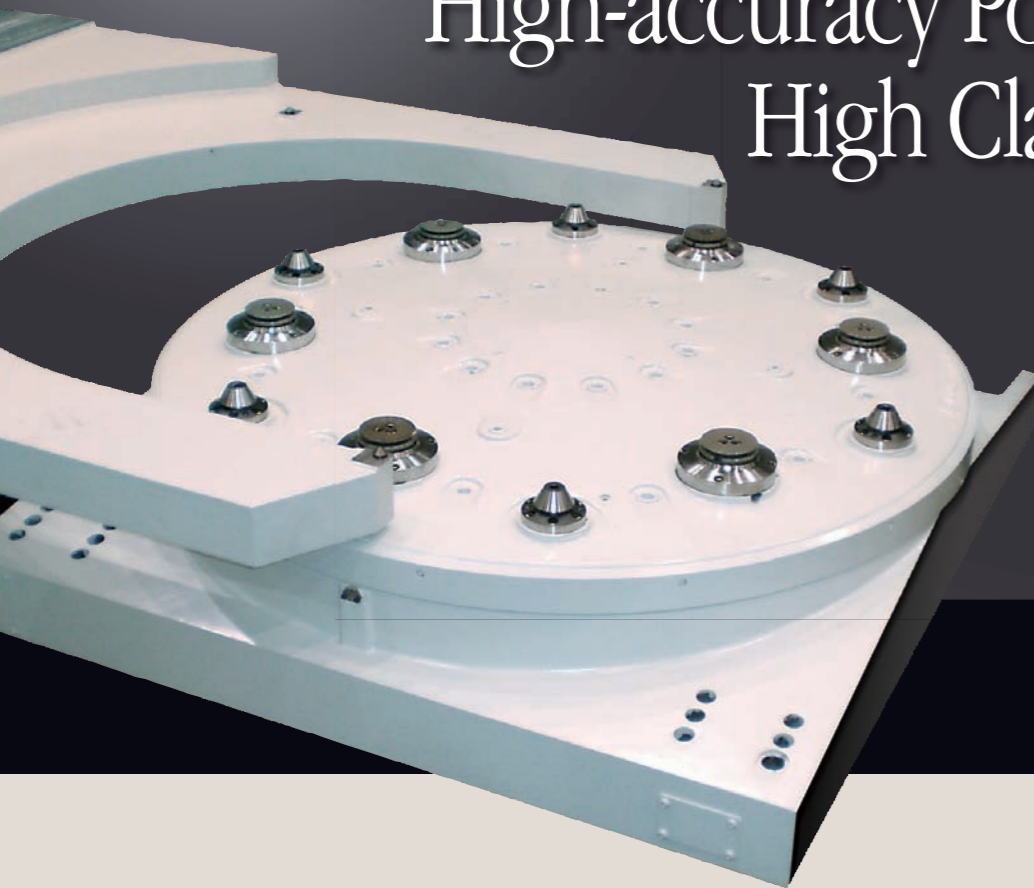

OKK's original six cylinder pallet clamping holds with a force of 284 kN and six taper cones produce high-accuracy positioning. The balanced clamping method and high clamping force delivers high cutting capability that is necessary for machining the large and heavy workpieces.

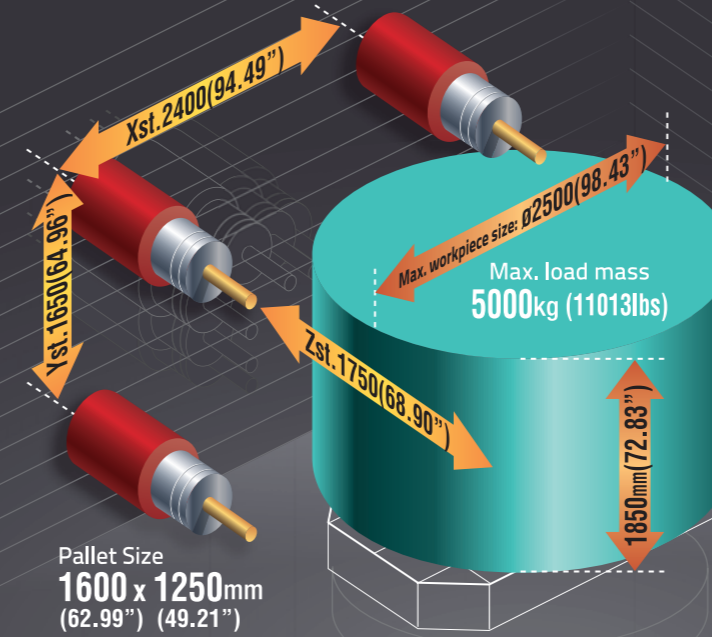

Hybrid guide supporting heavy workpiece Utilizing a large-diameter tapered roller bearing and the sliding guide surface on the B axis has produced a highly rigid table.

The built-in rotary table (BRT) is ideal for machining complicated workpieces and is included in the standard specification. It enables the 0.0001-degree minimum index angle.

Pallet Size
1600 x 1250mm
(62.99'') (49.21'')

Maximum Workpiece Size (Diameter x Height)
ø2500 x 1850mm
(98.43'') (72.83'')

Maximum Load Mass
5000kg (11013lbs)

*8000 kg (17621lbs) or 10000 kg (22026lbs) can be loaded optionally.
Note that the APC cannot be used for the 10000-kg (22026lbs) specification.

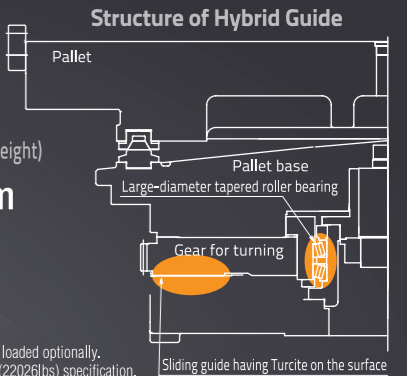

Wide Machining Area available for Large Workpieces

OKK pursued the ultimate superior accuracy, accessibility and operability by a thorough study of the heavy-duty cutting environment.

Forced Core Cooled Ball Screw and Double-anchoring Method

Lubrication Oil Temperature Controller



The forced core cooled ball screws are used on the X, Y and Z axes. Circulation of the temperature-controlled cooling oil on the surfaces of the ball screws, ball screw supports and motor mounting section minimizes the thermal displacement and provides continued accuracy over a long period of time.

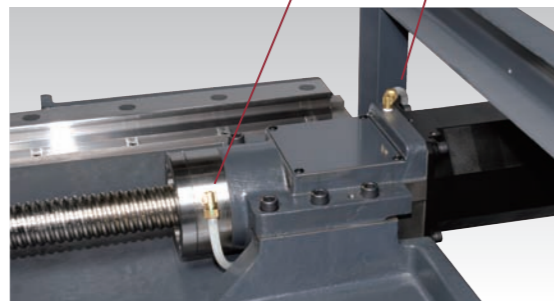
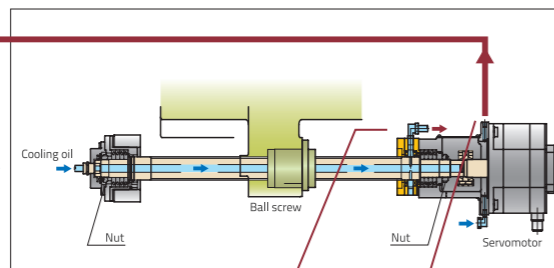

The double-anchoring method is effective for improving the feed mechanism's rigidity and accuracy. Use of the method for the X, Y and Z axes improves the fine-feed and lost-motion characteristics and drastically increases the circular cutting accuracy.

Cutting Data

Face Milling

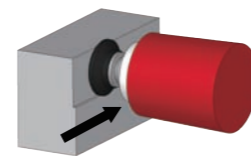

Type of machining	Face milling (ø125(5'')x6T)	
	Standard position (0 mm)(0'')	Extended position (300 mm)(11.81'')
Quill spindle position		
Spindle rotating speed	300min ⁻¹	300min ⁻¹
Width of cut	100mm (3.94'')	100mm (3.94'')
Depth of cut	6mm (0.24'')	2.5mm (0.098'')
Feed rate	1000mm/min (39.37ipm)	600mm/min (23.62ipm)
Cutting rate	600cm ² /min (36in ² /min)	150cm ² /min (9in ² /min)
Workpiece material	S45C	S45C

Grooving

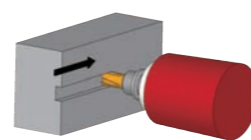

Type of machining	Grooving (ø50(2'')x6T)	
	Standard position (0 mm)(0'')	
Quill spindle position		
Spindle rotating speed	160 min ⁻¹	
Width of cut	50mm (1.97'')	
Depth of cut	25mm (0.98'')	
Feed rate	200mm/min (7.87ipm)	
Cutting rate	250cm ² /min (15in ² /min)	
Workpiece material	S45C	

Side Milling

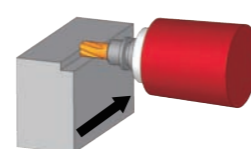

Type of machining	Side milling (ø50(2'')x6T)	
	Standard position (0 mm)(0'')	
Quill spindle position		
Spindle rotating speed	160 min ⁻¹	
Width of cut	25mm (0.98'')	
Depth of cut	50mm (1.97'')	
Feed rate	200mm/min (7.87ipm)	
Cutting rate	250cm ² /min (15in ² /min)	
Workpiece material	S45C	

The above values are reference values and consider them only as a guide for the cutting capability.

Accuracy

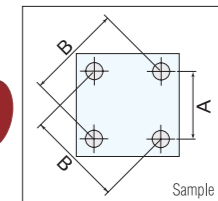
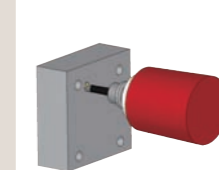

A	200.000 (7.87'')
B	282.843 (11.13555'')

Positioning Machining Accuracy (mm)			
Item	OKK tolerance	Example record	
Axial direction	0.015 (0.00059'')	-0.004 (-0.00016'')	
	0.015 (0.00059'')	-0.001 (-0.00004'')	
Diagonal direction	0.015 (0.00059'')	-0.001 (-0.00004'')	
Difference in diameter	0.010 (0.00039'')	0.003 (0.00012'')	

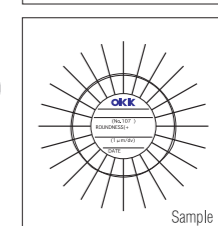

Circular Cutting Accuracy (mm)			
Item	OKK tolerance	Example record	
Circularity	0.015 (0.00059'')	0.00413 (0.00016'')	

Positioning Accuracy (mm)

Item	When linear scale is not used	When linear scale is used
Positioning accuracy	X:±0.0035(0.00014'') / full length	X:±0.0030(0.00012'') / full length
	Y:±0.0030(0.00012'') / full length	Y:±0.0025(0.00010'') / full length
	Z:±0.0030(0.00012'') / full length	Z:±0.0025(0.00010'') / full length
Repeated positioning accuracy	When linear scale is not used	When linear scale is used
	X/Y/Z:±0.0020(0.00008'') / full length	X/Y/Z:±0.0015(0.00006'') / full length

Remarks

- The data shown above as an example are based on the short-time machining. The values may vary in the continuous machining.
- The data shown above as an example were obtained under the OKK's in-house cutting test conditions. The values may vary with the condition of the cutting tools and fixtures.
- The above accuracy data are the laboratory data obtained by installing the machine according to the OKK's foundation drawing and carrying out the inspection based on the OKK's inspection standard in the environment with constant temperature.

Improved Reliability and Durability

We have considered the measures for chip removal, ease of maintenance, etc. and thoroughly pursued the production efficiency in the long hours of operation.

Design structure in consideration of safety, operability and even the environmental measures

We have improved largely the operability- and chip-processing-related problems that are specific to the large-size machines.

Thorough Chip Processing Measures

The shutter slots have been eliminated from the Y-axis upper and lower covers. Both the table main body and the Z-axis shutter have been steepened to avoid chips accumulation and improve the continuous machining reliability.

The wide troughs on both sides of the table can receive a large amount of chips. The chips and coolant in the troughs are completely transferred and ejected from the machine by means of the coil-type conveyors. The troughs also help to suppress the thermal displacement by sheltering the transfer of heat from chips and coolant to the bed.

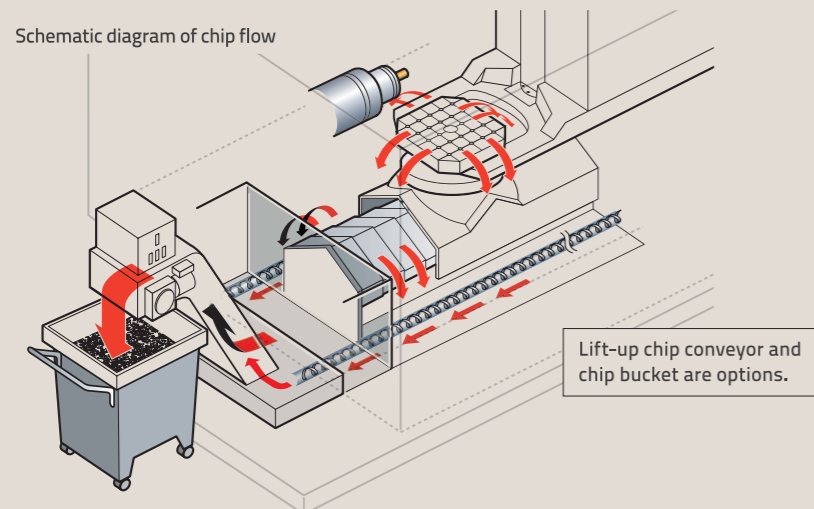

Ceiling Shower [Option]

A large amount of coolant can be jetted and sprayed evenly over the machine inside by using four 1.2-kW(1.6HP) pumps dedicated to the ceiling shower. The high-capacity ceiling shower washes away chips from fixtures and workpieces and prevents chips from accumulating.

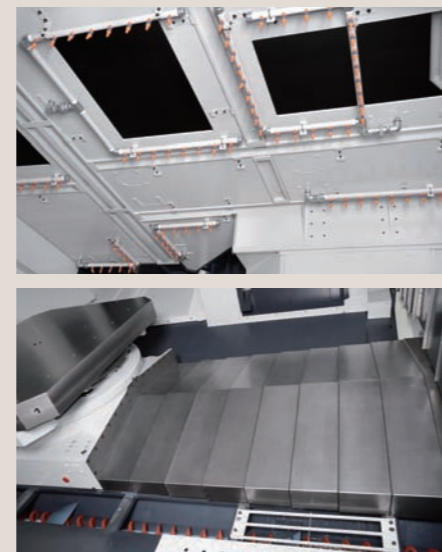

ATC [Automatic Tool Changer]

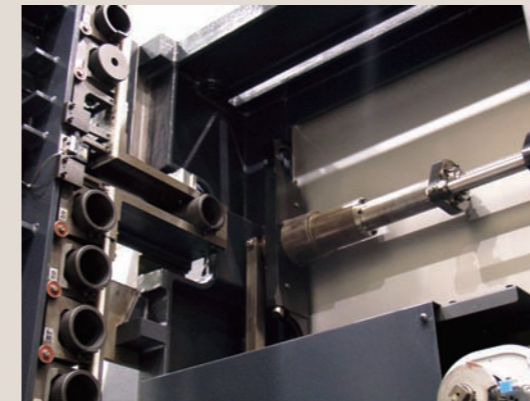

Consistent tool change operation and superior durability are ensured by use of the acknowledged OKK's original cam-controlled high-speed synchronizing tool changer (OKK patent). The variable-speed ATC function included in the standard specification allows setting at the time of tool registration for the heavy tools and large-diameter tools so that the ATC turning speed slows down automatically to change those tools smoothly.

Maximum Tool Diameter
∅115mm(4.53")
*∅300 mm (11.81") when the adjoining tool pots are empty.

Tool Exchange Time (tool-to-tool)
3.8s

Maximum Tool Length
600mm(23.62")
*For the multi-magazine that can store 176 or more tools, the maximum tool length for the tools stored in the 3rd or later magazines is restricted to 500 mm.

Tool Exchange Time (cut-to-cut)
11.0s

Maximum Tool Mass
30kg(66.1lbs)

Maximum Tool Moment
29.4N·m
(21.7ft·lbs)

APC [Automatic Pallet Changer]



APC [Automatic Pallet Changer]

The APC mechanism of HM1600 uses the direct-turn method consisting only of the pallet lift and turning mechanism so that the pallet exchange time is reduced and space-saving is realized. It can handle the table's maximum load mass of 8000 kg (17621lbs) [option]. Since its design has taken into consideration the expansion for automation (6APC with automatically transferred pallet), it is easily compatible with the line configuration.

Maintenance

The daily inspected equipment are aggregated and installed below the lower steps for ease of maintenance.

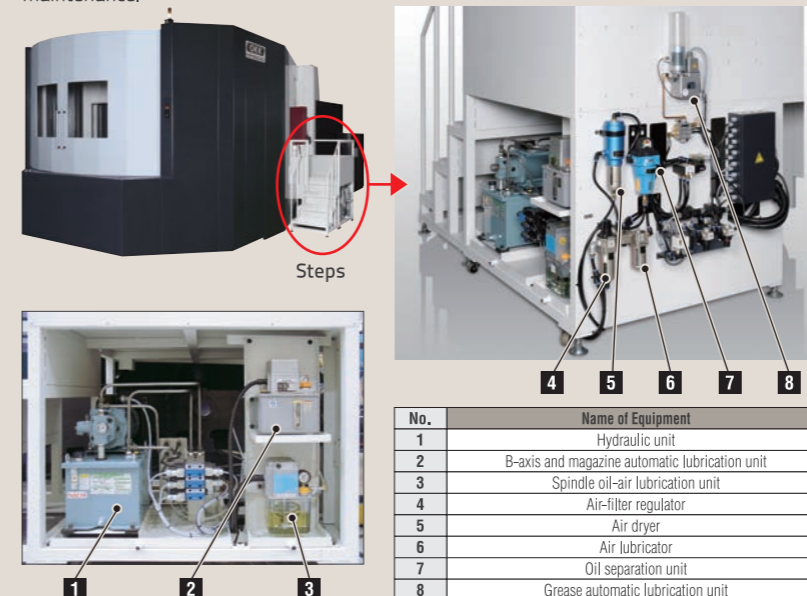

Lift-up Chip Conveyor [Option]

We can provide various types of lift-up chip conveyors.

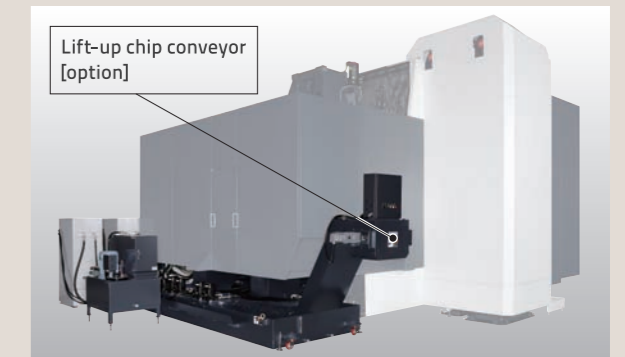

Machine Dimensions

Front View

Side View

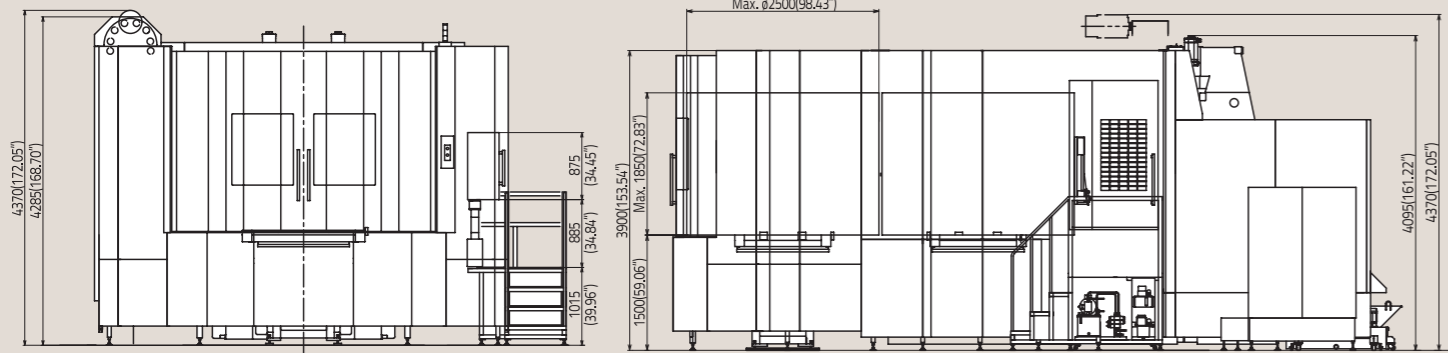

Floor Space Diagram

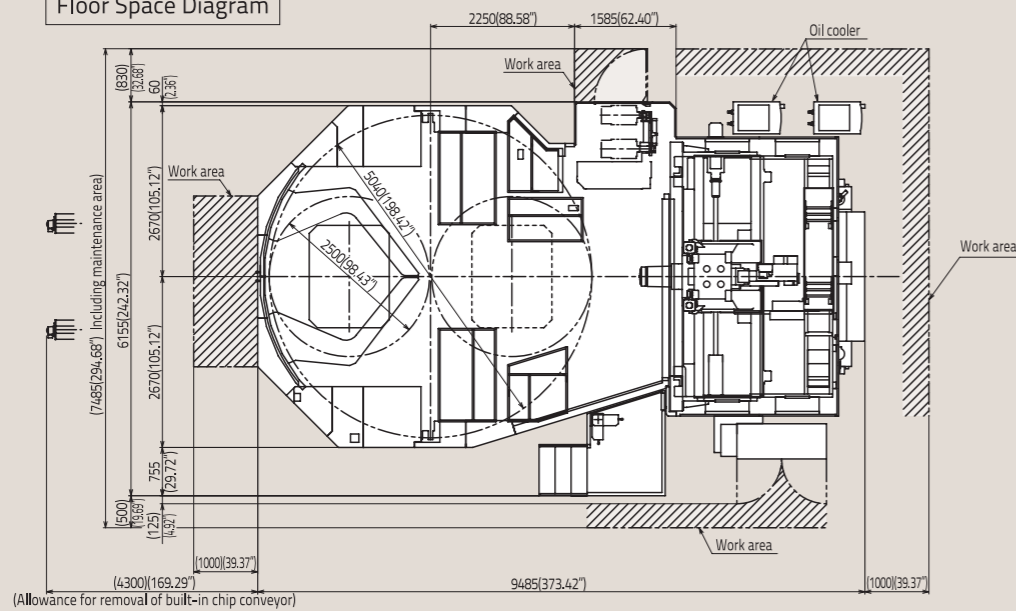

Floor Space Diagram [Option]

Chip-conveyor Specification

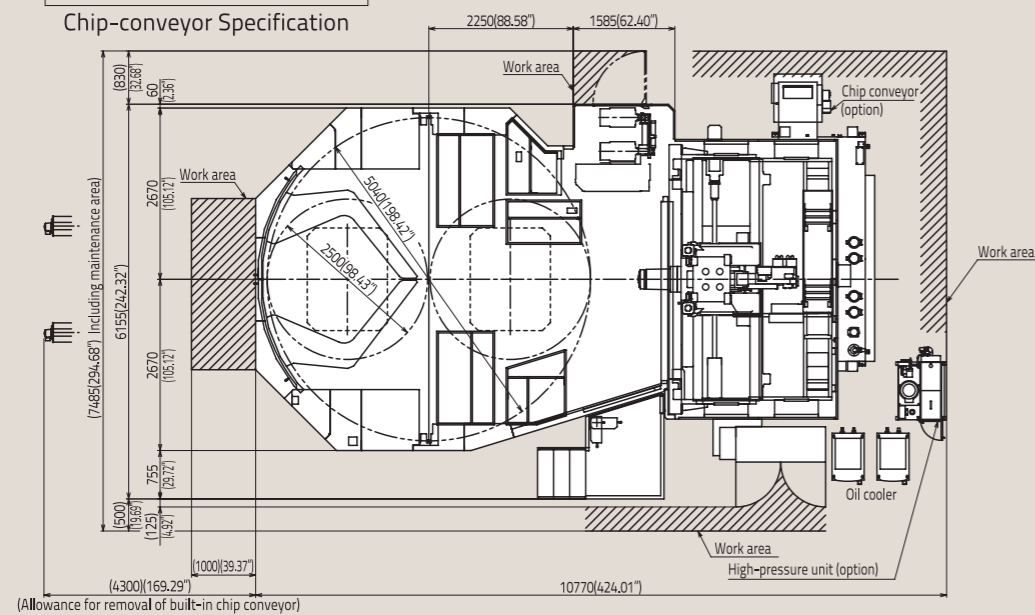

Restrictions on Workpiece

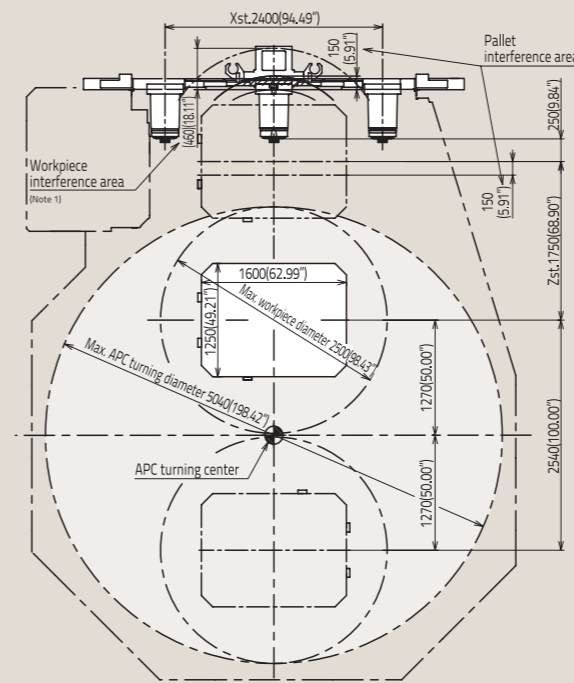

Note 1: When the APC operation is used, do not load a workpiece that exceeds the range of the maximum APC turning diameter shown above.

Stroke Diagram

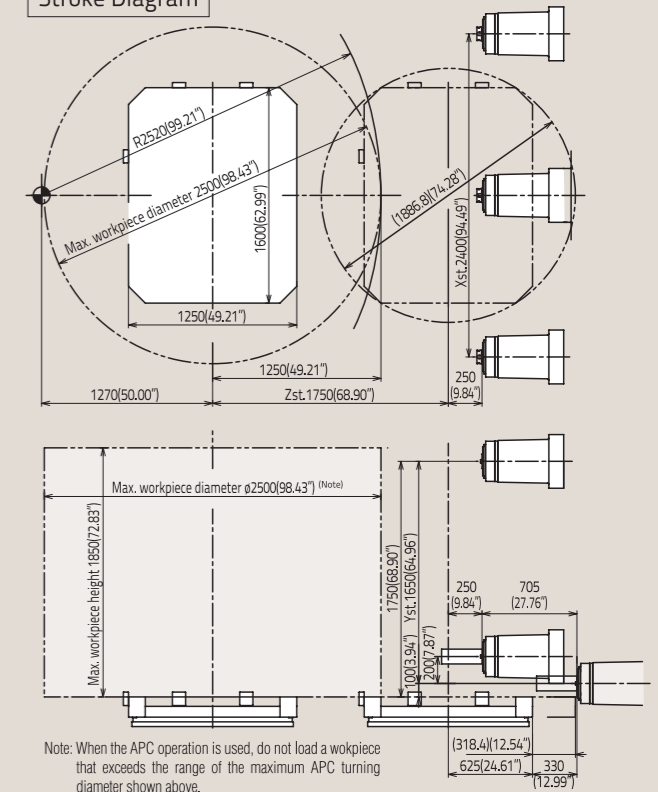

Note: When the APC operation is used, do not load a workpiece that exceeds the range of the maximum APC turning diameter shown above.

Spindle Shape and Dimensions

12000-min⁻¹ MS Specification

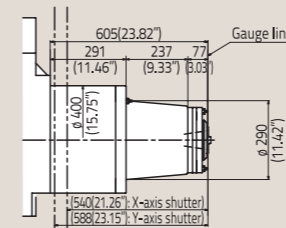

8000-min⁻¹ Gear Spindle Specification

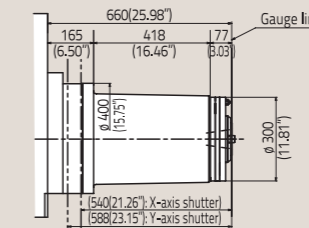

4000-min⁻¹ Two Position Spindle Specification

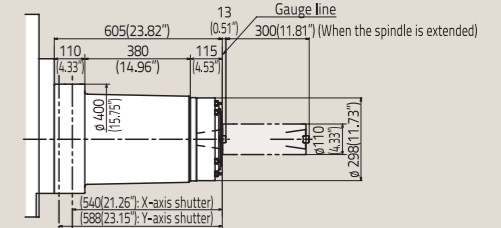

Restrictions on Tool

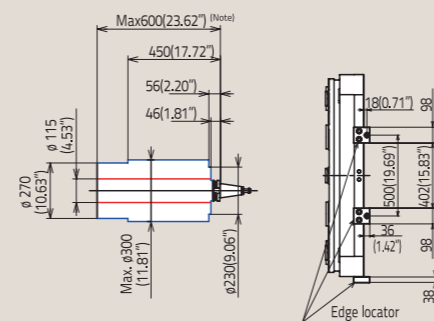

Note: For the multi-magazine that can store 176 or more tools, the maximum tool length for the tools stored in the 3rd or later magazines is restricted to 500 mm(19.69).

Screw Hole Specification [Standard]

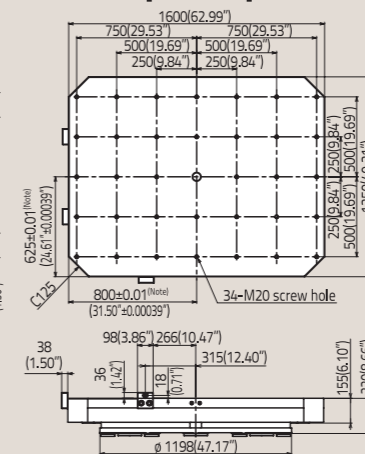

Note: This dimension is the dimension between the center of rotation and the edge locator. Please also note that the pallet center hole does not always correspond to the center of rotation.

Pallet Dimensions

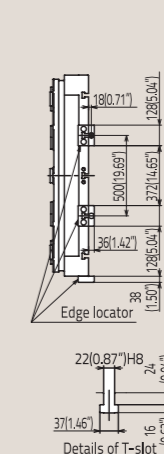

T-slot Specification [Option]

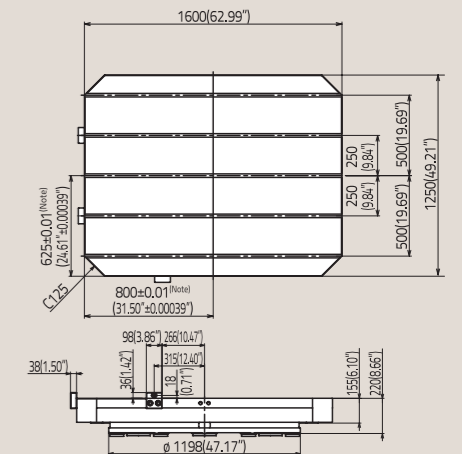

Note: This dimension is the dimension between the center of rotation and the edge locator.

HM1600/10t

10000-kg(22026lbs) Maximum Load Mass Specification

The 10000-kg(22026lbs) maximum load mass specification machine can be provided for machining dies and molds and large and heavy parts.
 (APC unit is not available. Rapid traverse rate: 20000 mm/min(787.40ipm) for X, Y and Z axes and 2.5 min⁻¹ for B axis)

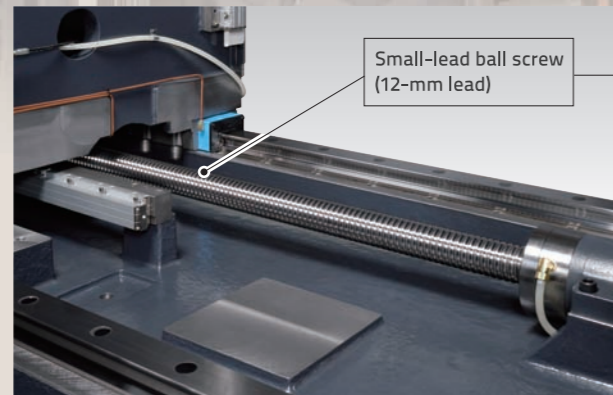
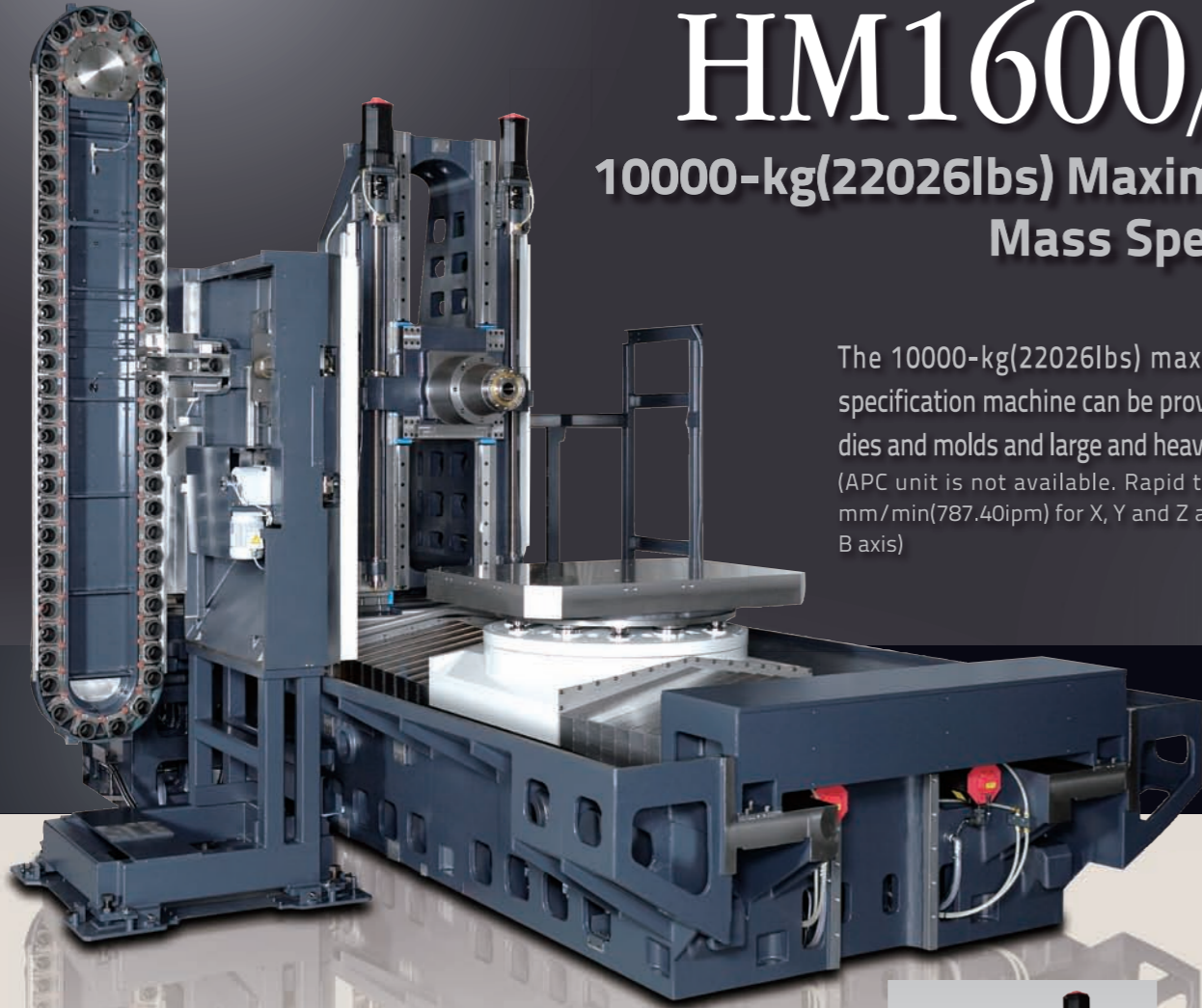

Small-lead ball screw (12-mm lead)

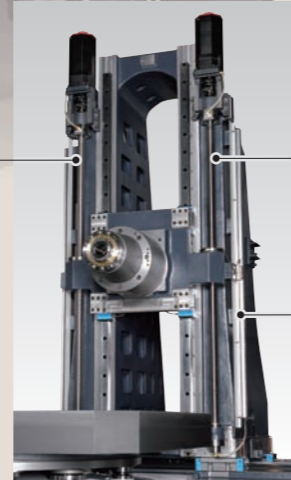

Small-lead ball screw (12-mm lead)

Linear scale [option]

Main Specification

Item	Unit	10000-kg(22026lbs) Specification
Travel on X axis (Column's longitudinal direction)	mm	2400(94.49")
Travel on Y axis (Spindle head's vertical direction)	mm	1650(64.96")
Travel on Z axis (Pallet's cross direction)	mm	1750(68.90")
Distance from table top surface to spindle center	mm	100(3.94")~1750(68.90")
Distance from table center to spindle nose	mm	250(9.84")~2000(78.74")
Table (pallet) work surface area	mm	1600(62.99")×1250(49.21")
Max. mass of load on table (pallet)	kg	10000(22026lbs)
Max. workpiece size (diameter × height)	mm	∅2500(98.43")×1850(72.83")

Item	Unit	10000-kg(22026lbs) Specification
Rapid traverse rate	mm/min	X/Y/Z: 20000(787.40ipm)
Number of stored tools	tools	60
Maximum tool diameter	mm	∅115(4.53") (∅300 mm(11.81") when the adjoining tool pots are empty.)
Maximum tool length (from gauge line)	mm	600(23.62")
Maximum tool mass	kg	30(66.1lbs)
Required floor space	mm	6625(260.83")×7230(284.65")
Machine height	mm	4370(172.05")
Machine mass	kg	40000(88105lbs)

10000-kg(22026lbs) Specification Machine Main Dimensions

Workpiece Loading Diagram

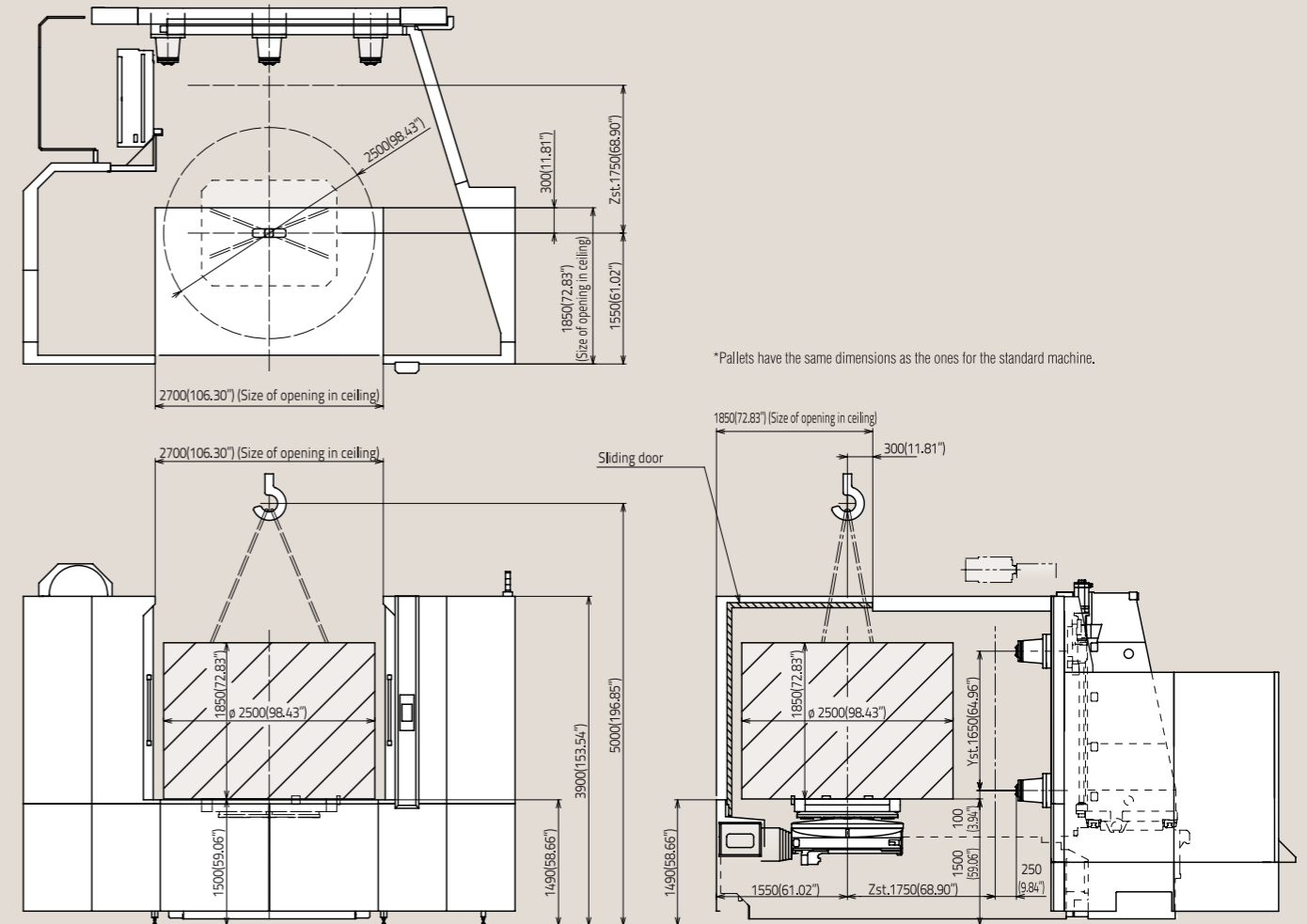

*Pallets have the same dimensions as the ones for the standard machine.

Floor Space Diagram [Option]

Chip-conveyor Specification

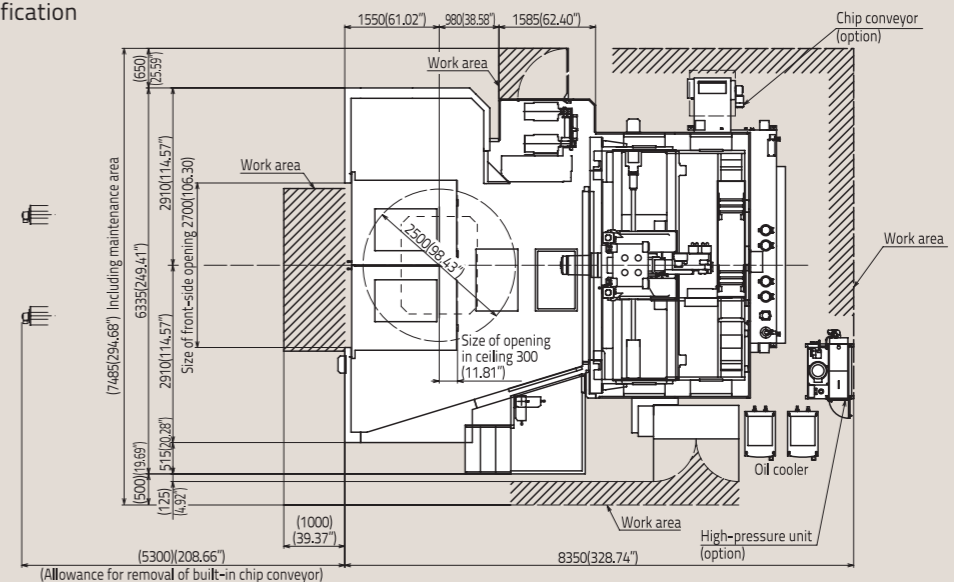

(Allowance for removal of built-in chip conveyor)

**8-10, KITA-ITAMI, ITAMI
HYOGO, JAPAN**

Overseas Sales Department
TEL:(81)72-771-1112/1143
FAX:(81)72-772-7592
<http://www.okk.co.jp>
E-mail:ovsd@okk.co.jp

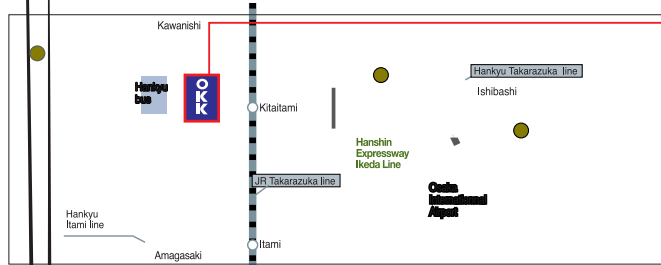

Technical center is for test cutting, demonstration and training.
S-plant is for machining and assembly of spindles and
W-plant is for final assembly of large sized machining

INAGAWA PLANT:
8-10, KITA-ITAMI, ITAMI, HYOGO 664-0831 JAPAN
TEL:(81)72-782-5121
FAX:(81)72-772-5156
E-mail:eigibu@okk.co.jp

**OKK A DIVERSIFIED MANUFACTURER OF
MACHINE TOOLS**

Specializes In:

- Machining centers
- Graphite cutting machining centers
- Grinding centers
- CNC Milling machines
- Conventional milling machines
- Total die and mold making systems
- Flexible manufacturing cells and systems

Other Products Include:

- Textile Machinery
- Water Maters

NOTE :

OKK reserves the right to change the information contained in this brochure without notice.
OKK is not responsible to make changes to previously sold machines or accessories.

The export of this product is subject to an authorization from the government of the exporting country.
Check with the government agency for authorization.

OKK USA CORPORATION

100 REGENCY DRIVE, GLENDALE HEIGHTS, IL 60139 USA
TEL:(1)630-924-9000
FAX:(1)630-924-9010
<http://www.okkcorp.com>
E-mail:okkusa@okkcorp.com

OKK USA WESTERN REGIONAL OFFICE(LA)

17971 SKY PARK CIRCLE, SUITE D, IRVINE CA 92614 USA
TEL:(1)949-851-6800
FAX:(1)949-851-6888

OKK CANADA OFFICE(CANADA)

7449 AUBURN ROAD, UNIT 1B HORNBY, ONTARIO, LOP 1E0, CANADA
TEL:(1)905-639-9784
FAX:(1)905-639-9503

OKK EUROPE GmbH

HANSEMANNSTR, 33 41468 NEUSS GERMANY
TEL:(49)2131-29868-0
FAX:(49)2131-29868-41
<http://www.okkeurope.com>
E-mail:info@okkeurope.com

THAI OKK MACHINERY CO., LTD.

KUMTHORN HOLDING BUILDING 2nd FLOOR 897-897/1 RAMA III ROAD BANGPONGPANG, YANNAWA, BANGKOK 10120 THAILAND
TEL:(66)2-683-2160-2
FAX:(66)2-683-2163

PT. OKK INDONESIA

WISMA NUSANTARA BUILDING 12 FLOOR.
JL.M.H.THAMRIN No.59, JAKARTA. 10350 INDONESIA
TEL:(62)21-390-2563
FAX:(62)21-390-2565

OKK(SHANGHAI) CO., LTD.

ROOM C303,NO.1221 HAMI ROAD CHANGNING DISTRICT SHANGHAI P.C200335 CHINA
TEL:(86)21-62700930
FAX:(86)21-62700931
<http://www.okk.com.cn>
E-mail:shanghai@okk.com.cn

OKK(SHANGHAI) CO., LTD. BEIJING BRANCH

ROOM 1905, EAST OCEAN CENTER, No.24A JIAN GUO MEN STREET CHAO YANG DISTRICT, BEIJING, 100004 CHINA
TEL:(86)10-6515-0502/0702
FAX:(86)10-6515-5087
E-mail:okk_beijing@okk.com.cn

OKK CORPORATION SEOUL BRANCH

1203, E & C DREAM TOWER 8, 327-27, DASAN-DONG, GEUMCHEON-GU, SEOUL, 153023, KOREA
TEL:(82)2-855-0416
FAX:(82)2-855-0426